

exkal

EXPOSICIÓN Y CONSERVACIÓN
DE ALIMENTOS, S.A.



ISLA INTEGRAL
INTEGRAL ISLAND
ILOT GROUPE LOGE

TENERIFE

IG5 / IG1 / IG15

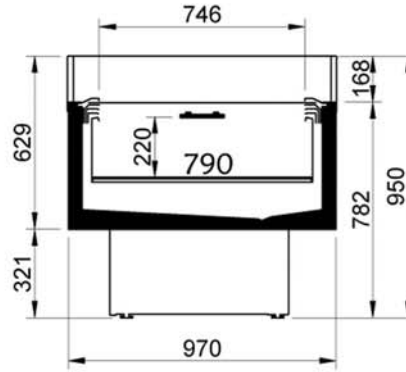

-23/-25 °C & -1 / +1°C



IG5 BT
 IG1 MT
 IG15 BT&MT

CARACTERÍSTICAS TÉCNICAS / TECHNICAL DATA / CARACTERISTIQUES TECHNIQUES

IG5 / IG1 / IG15

Módulo / Module	2	3	4
Longitud exterior / Exterior length / Extérieur Longueur (mm)	1510	2010	2510
Longitud interior / Interior length / Intérieur Longueur (mm)	1400	1900	2400
Superficie exposición / Display surface / Superficie exposition (m ²)	1.11	1.51	1.90
TDA (m ³)	1.05	1.42	1.79
Volumen bruto / Gross volume / Volume brut (dm ³)	245	332	419
Nivel sonoro / Sound level / Bruit (dBA)	<52	<52	<52
Peso / Weight / Poids (Kg)	150 (IG15 154)	195 (IG15 201)	247 (IG15 250)
Temperatura de aplicación / Running temperature / Température d'application	-23 / -25°C (5)(15) -1 / +1°C (1)(15)		
Condiciones ambientales / Ambient conditions / Condition d'ambiance	Clase / Class / Classe 3 (25°C - 60% H.R.)		

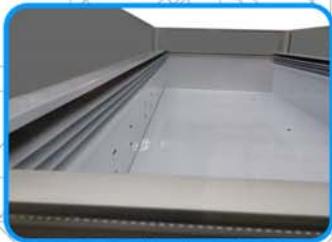

EXPOSICIÓN Y CONSERVACIÓN DE ALIMENTOS, S.A.

Ficha TENERIFE EDO
 Sujeto a posibles modificaciones sin previo aviso.

輝和陳列設備有限公司
Fixwell Display System Co., Ltd.

Hong Kong Representative:
 Fixwell Display System Co., Ltd
 Unit 1401, Westlands Centre,
 20 Westlands Road, Quarry Bay, Hong Kong.
 tel.: +852 2811 9381
 e-mail: sales@fixwell.com.hk
 http://www.fixwell.com.hk